

Those Speed Cameras Are Everywhere: Automated Speed Monitoring Law, Enforcement, and Physics in Maryland

Steven A. Glazer

Follow this and additional works at: <http://digitalcommons.law.umaryland.edu/jbtl>

 Part of the [Transportation Law Commons](#)

Recommended Citation

Steven A. Glazer, *Those Speed Cameras Are Everywhere: Automated Speed Monitoring Law, Enforcement, and Physics in Maryland*, 7 J. Bus. & Tech. L. 1 (2012)

Available at: <http://digitalcommons.law.umaryland.edu/jbtl/vol7/iss1/1>

This Articles & Essays is brought to you for free and open access by the Academic Journals at DigitalCommons@UM Carey Law. It has been accepted for inclusion in Journal of Business & Technology Law by an authorized editor of DigitalCommons@UM Carey Law. For more information, please contact smccarty@law.umaryland.edu.

Those Speed Cameras are Everywhere: Automated Speed Monitoring Law, Enforcement, and Physics in Maryland

I. INTRODUCTION

THE STATE OF MARYLAND AND ITS CASH-STRAPPED COUNTIES AND municipalities are rapidly taking to the latest local traffic enforcement tool in America—speed cameras.¹ The state and local governments are teaming up with a growing technology industry to install stationary and mobile automated speed monitoring devices within their jurisdictions to catch drivers exceeding the speed limit on their streets and highways.² The combined radar- or laser-and-camera systems garner impressive revenues from high volumes of relatively small fines.³ The \$40 fines themselves are just expensive enough to hurt the average person, but not high enough for that person to take off from work or home responsibilities to contest the

© 2012 Steven A. Glazer.

* Steven A. Glazer is an Administrative Law Judge with the Federal Energy Regulatory Commission and an Adjunct Professor of Law at the University of Maryland School of Law. The views that he expresses in this article are his own and do not reflect the views or positions of the Federal Energy Regulatory Commission, its Chairman and Commissioners, or any other agency or instrumentality of the Federal Government.

1. See RICHARD ROMER ET AL., EVALUATION OF MONTGOMERY COUNTY'S SAFE SPEED PROGRAM, OFFICE OF LEGIS. OVERSIGHT REP. NO. 2010-3, at 14 (Md. 2009) (noting that as of 2009, forty-eight jurisdictions within eleven states and the District of Columbia employed mobile and/or fixed speed cameras to photograph vehicles traveling in excess of the legal limit). In August 2011, Prince George's County became the latest jurisdiction in Maryland to join the nationwide trend. Gwendolyn Glenn, *Speed Cameras Live in Prince George's County*, BALTIMORE SUN, Aug. 22, 2011, <http://www.baltimoresun.com/explore/howard/news/community/ph-ll-news-brief-cameras-0825-20110822,0,6149608.story>.

2. See Kris Van Cleave, *Money from Maryland Speed Cameras Goes to Contractor*, WJLA ABC-7 NEWS (May 6, 2011, 10:11 PM), <http://www.wjla.com/articles/2011/05/contractor-gets-money-from-maryland-speed-cameras-60226.html> (reporting that Maryland works closely with Affiliated Computer Services, Inc. to run its speed camera program).

3. See MD. CODE ANN., TRANSP. § 21-809(c), (h) (West 2010) (limiting civil penalty to a maximum \$40 fine and disallowing a point accrual on the violator's driving record). Maryland has generated over \$11 million in profits since the inception of the speed camera program. Cleave, *supra* note 2.

fine in court. Hence, they are largely paid, generating a cash bonanza for the city or town.⁴

There are some positives to this trend.⁵ It frees local police to do other things besides manning speed traps, although they still have to spend time defending speed camera tickets in court.⁶ It forces drivers to be more speed-conscious and induces them to obey speed limits, lowering the potential for roadway accidents.⁷ It provides large amounts of revenue to local governments, generally from out-of-town drivers who, unlike residents, are unaware of where the speed cameras are, at a time when tax yields have fallen with hard times.⁸

Although the negatives appear minimal in comparison to the positives, the negatives are decidedly present. There is an inherent failing of speed camera systems that induces irate motorists to fight the tickets in court despite the miniscule penalty and the bother of going to court.⁹ As a result, speed camera violations now clog the district courts of Maryland and normally prudent and reasonable drivers feel preyed upon by the ubiquitous traps.¹⁰

This article will explore the pros and cons of Maryland's speed camera laws.¹¹ It will examine the law, the technology involved, and the issues arising from the initiation of automated speed monitoring programs and their enforcement.¹² It will also look at the effect of the programs on Maryland's district courts, which are charged by the law with hearing contested speed camera cases.¹³

Individual automated speed enforcement violations, which are civil in nature and do not add points to a violator's driving record, are probably too insignificant

4. See ROMER ET AL., *supra* note 1, at 37 (reporting that from fiscal year 2007 through 2009, less than 1% of drivers in Montgomery County appealed the citation and on appeal, the district court found 99.7% guilty of violating the speed limit).

5. See *id.* at 9 (identifying the benefits of speed cameras as deterring speeding, modifying driver behavior, providing safer and consistent speed enforcement, and relieving the burden on police resources).

6. From fiscal years 2007 through 2009, 3,098 citations were appealed in Montgomery County. *Id.* at 38.

7. *Id.* (citing WORLD HEALTH ORG., WORLD REPORT ON ROAD TRAFFIC INJURY PREVENTION: SUMMARY 29 (2004), available at http://www.who.int/violence_injury_prevention/publications/road_traffic/world_report/summary_en_rev.pdf). The Evaluation of Montgomery County's Safe Speed Program noted that speed cameras reduce serious traffic injuries and deaths by 14% as compared to traditional enforcement methods that achieve a 6% reduction. *Id.*

8. See *generally id.* at 10 (acknowledging that the primary controversy over speed cameras is whether the programs are designed to generate revenue or to increase safety).

9. See, e.g., *id.* at 36–38 (reporting that although only ten citation appeals were successful, 3,098 people in Montgomery County contested citations between 2007 and 2009 rather than pay a \$40 fine, accept guilt, and waive the right to a hearing).

10. See, e.g., *Maryland Speed Camera Program Faces New Legal Challenge*, CARROLL STANDARD (Apr. 30, 2010, 4:30 PM), <http://carrollstandard.com/news/in-other-news/8398-maryland-speed-camera-program-faces-new-legal-challenge.html> (describing a 2010 case in which the outraged driver conducted research of state and local laws and successfully argued that “[t]he camera images were obtained illegally because the camera was not [calibrated] in accordance with state law”).

11. This article will not cover the red light camera laws, which are governed by different statutes, technology, and, arguably, different principles of physics.

12. See *infra* Parts II–IV.

13. See *infra* Parts II.C–D, V.

for attorneys to develop into lucrative practices.¹⁴ This article, nevertheless, may be worthwhile as a guide to the layman seeking to be better informed or eager to contest an unjustified speed camera citation. Despite the small penalty, a large number of drivers are showing up in district courts to contest the citations out of indignation at being served with an unjust fine when they are sure that they were not speeding, or when the fine is invalid for other reasons.¹⁵ Therefore, even though speed camera violations appear to be very minor infractions, they are striking a chord with the public that is likely to generate considerable future legal interest in this topic.

II. MARYLAND LAW

Two provisions of the Maryland Transportation Code that were enacted in 2009 have been applied to most of the speed camera cases in the state.¹⁶ One of the laws is designed to allow county governments throughout Maryland, and the many incorporated cities and towns of Prince George's County in particular, to run speed camera programs on local roads and in designated school zones.¹⁷ The other law allows the state and counties to do the same in highway work zones.¹⁸ Specifically, section 21-809 of the Maryland Transportation Article authorizes the creation of speed monitoring programs by counties, in the school zones of Prince George's County municipalities, and on roads within "institutions of higher education" in Prince George's County.¹⁹ Section 21-810 of the Code authorizes their

14. Speed Monitoring Systems and Work Zone Speed Control Systems are governed by the Maryland Transportation Code's sections 21-809 and 21-810, respectively. See MD. CODE ANN., TRANSP. §21-809(c), (h) (West 2010) (noting that fines may not exceed \$40 for civil penalties, and such civil penalties are not moving violations that add points to a driver's record, respectively).

15. See ROMER ET AL., *supra* note 1, at 38. In a limited number of instances, the district court has dismissed cases in which there is evidentiary support that either the vehicle or the license plates were stolen, the driver was not driving at the time of the citation, the speed limit signs were obscured by trees, or the driver was transporting a passenger to the emergency room. *Id.*

16. See MD. CODE ANN., TRANSP. §§ 21-809, -810 (West 2010) (setting forth provisions regarding speed monitoring systems and use of speed control systems in work zones).

17. *Id.* § 809(b)(1)(vi).

This section applies to a violation . . . recorded by a speed monitoring system that meets the requirements of this subsection and has been placed . . . [i]n Montgomery County, on a highway in a residential district . . . with a maximum posted speed limit of 35 mph . . . [i]n a school zone . . . [or i]n Prince George's County, on that part of a highway located within the grounds of an institution of higher education . . . or within one-half mile of the grounds of a building or property used by the institution of higher education.

Id.

18. *Id.* § 810(b)(1). The statute defines a "work zone" as "a segment of a highway . . . identified as a temporary traffic control zone by traffic control devices that are placed or installed in general conformance with the State manual and specifications adopted for a uniform system of traffic control devices" and "[w]here highway construction, repair, maintenance, utility work, or a related activity, including the placement, installation, maintenance, or removal of a work zone traffic control device, is being performed regardless of whether workers are present." *Id.* § 810(a)(6).

19. *Id.* § 809(b)(1)(vi)(3) (West 2010).

implementation in work zones on expressways and controlled-access highways.²⁰ Violations and fines are processed the same way under both sections.²¹

A. *Local Roads and School Zones in Counties and Municipalities*

Section 21-809 allows local jurisdictions to use speed monitoring systems when “authorized by the governing body of the local jurisdiction by local law enacted after reasonable notice and a public hearing.”²² In general, all Maryland counties are entitled to install such systems on any of its roads, including on state highways with the permission of the State Highway Administration.²³ Prince George’s County, however, is given a special status under the law.²⁴ Municipalities in Prince George’s County, as well as the county itself, may also implement such systems within their own boundaries, but only in designated school zones and parts of highways located within the grounds of certain “institutions of higher education.”²⁵

Speed monitoring systems are defined in the law as “device[s] with one or more motor vehicle sensors producing recorded images of motor vehicles traveling at speeds at least 12 mph above the posted speed limit.”²⁶ The “recorded images” that they produce must show (1) “the rear of a motor vehicle;” (2) “at least two time-stamped images of the motor vehicle that include the same stationary object near the motor vehicle;” and (3) “on at least one image . . . a clear and legible identification of the entire registration plate number of the motor vehicle.”²⁷

A “speed monitoring system operator” is defined in the law as “a representative of an agency or contractor that operates a speed monitoring system,” which can be the county or city police department.²⁸ If the municipality has no police force, an “agency” can be designated by the locality to implement the system on its behalf.²⁹ Speed monitoring system operators must be trained and certified by the manufacturer of the device in the procedures for setting up and operating them, and must fill out and sign a daily set-up log for the device that “[s]tates that the speed monitoring system operator successfully performed the manufacturer-

20. *Id.* § 810(b)(1)(i)–(iii).

21. *See id.* §§ 809(c)(2), -810(c)(2) (authorizing a maximum civil penalty of a \$40 fine for citations in either a speed or a work zone).

22. *Id.* § 809(b)(1)(i).

23. *See id.* § 810(b)(1)(ii) (setting forth approval and notice requirements for a local jurisdiction to implement a speed monitoring system).

24. *Id.* §§ 809(b)(1)(iii), -809(b)(1)(vi)(3).

25. *Id.* §§ 809(b)(1)(iii)(2)(A), -809(b)(1)(vi)(3).

26. *Id.* § 809(a)(5).

27. *Id.* § 809(a)(4)(ii)(1)–(3). The statute defines “recorded images” as images captured by a speed monitoring system in “1. [a] photograph, 2. [a] microphotograph; 3. [a]n electronic image; 4. [v]ideotape; or 5. [a]ny other medium.” *Id.* § 809(a)(4)(i).

28. *Id.* §§ 809(a)(2), -809(a)(6).

29. *Id.* § 809(a)(2)(i)–(ii).

specified self-test of the speed monitoring system prior to producing a recorded image.”³⁰

The speed monitoring systems must “undergo an annual calibration check performed by an independent calibration laboratory” that certifies the device’s performance.³¹ Both the operator’s daily log and the certificate of calibration are admissible as evidence in court proceedings for violations.³² If an alleged violator desires the operator to be present and testify at trial, he or she must notify the court and the state in writing no later than 20 days before trial.³³

“Before activating an unmanned speed monitoring system, the local jurisdiction [must] publish notice of [its] location . . . on its website and in a [local] newspaper,” install proper signage indicating that the system is in use in a school zone or “institution of higher education,” and operate the system “only Monday through Friday between 6:00 a.m. and 8:00 p.m.”³⁴ For the first 30 days of the system’s implementation, local jurisdictions may issue only non-monetary warning citations to violators.³⁵

B. Work Zones on Expressways and Controlled-Access Highways

Section 21-810 authorizes the state and local jurisdictions to operate speed monitoring systems within work zones on expressways or controlled-access highways on which motorists travel at speeds of 45 mph or greater.³⁶ Any local police department, state police department, or Maryland State Highway Administration contractor may operate speed monitoring systems in such work zones.³⁷ They may be operated wherever “highway construction, repair, maintenance, utility work or related activit[ies]” are being performed “regardless of whether workers are present.”³⁸

The speed monitoring devices record images the same way as the ones authorized in section 21-809.³⁹ A work zone speed control system operator must be trained and certified and must sign a daily set-up log in the same fashion as his or her counterpart under section 21-809.⁴⁰ The devices must be calibration-tested and certified annually by an independent calibration laboratory, and both the operator’s daily logs and calibration certificates are admissible as evidence in court

30. *Id.* § 809(b)(2)(i)–(iii), (3)(i).

31. *Id.* § 809(b)(4)(i).

32. *Id.* § 809(b)(3)(iii), (4)(i), (ii)(2).

33. *Id.* § 809(e)(2).

34. *Id.* § 809(b)(1)(vii)–(viii).

35. *Id.* § 809(b)(1)(v).

36. *Id.* §§ 21-810(a)(6), (b)(1)(i)–(iii).

37. *Id.* at § 810(a)(8).

38. *Id.* at § 810(a)(6)(ii).

39. *Id.* § 810(a)(4); *see also supra* note 30 and accompanying text.

40. MD. CODE ANN., TRANSP. § 21-810(b)(4)–(5) (West 2010).

proceedings for violations.⁴¹ Unlike the speed monitoring systems of section 21-809, however, the work-zone speed monitoring systems of section 21-810 may not operate unmanned; they may be used only “[w]hen being operated by a work zone speed control system operator.”⁴²

C. *Violations, Fines, and Enforcement*

The fine for exceeding the posted speed limit by 12 mph or more is a penalty of \$40 under both speed monitoring system statutes.⁴³ Under section 21-809, “if a contractor operates a speed monitoring system on behalf of a local jurisdiction or police department, the contractor’s fee may not be contingent on the number of citations issued or paid.”⁴⁴

Failure to pay the penalty or contest liability in a timely manner amounts to an admission of liability and may result in the refusal of the Motor Vehicle Administration to register the motor vehicle or to suspend the registration altogether.⁴⁵ However, speed monitoring enforcement citations are not treated like ordinary speeding tickets;⁴⁶ rather than misdemeanors or felonies, they are civil in nature, do not result in the assessment of points on a driver’s record, and may not be considered in the provision of motor vehicle insurance coverage.⁴⁷

The Maryland district courts have jurisdiction over speed monitoring enforcement cases.⁴⁸ Both enabling statutes set forth the same standards of evidence and defenses that are permitted in a district court trial of a contested citation.⁴⁹ In addition to the usual admission into evidence of the speed monitoring system operator’s daily log and the annual calibration certifications of the monitoring device, the driver may request up to 20 days before trial that a speed monitoring system operator testify in court.⁵⁰ On the plaintiff municipality’s side, a certificate alleging that a violation occurred that has been sworn to or affirmed by a police officer or agent of the enforcing agency, “based on inspection of the recorded images produced by the speed monitoring system” or “a work zone speed control system,” is considered sufficient evidence of the facts stated therein, and the presence or testimony of the system operator of the device is not required.⁵¹ In

41. *Id.* § 810(b)(5)(iv), (6).

42. *Compare id.* § 809(b)(1)(vii), *with id.* § 810(b)(2)(ii).

43. *Id.* §§ 809(a)(5), -809(c)(2), -810(b)(3), -810(c)(2).

44. *Id.* §§ 809(j)(2), -810(j)(2).

45. *Id.* §§ 809(d)(1)(xi), -810(d)(1)(xi).

46. *See id.* §§ 809(h), -810(h) (discussing statutory differences between the civil nature of speed camera violations and the traditional speeding violations).

47. *See* TRANSP. §§ 21-809(h), -810(h) (stating that a speed camera violation is not a moving violation and may not be recorded on the driving record of the owner or the driver of the vehicle).

48. MD. CODE ANN., CTS. & JUD. PROC. § 4-401(13) (West 2010) (conferring jurisdiction on the district court for a civil infraction under §21-809 and §21-810).

49. TRANSP. §§ 21-809(e)–(f), -810(e)–(f).

50. *Id.* §§ 809(e)(2), -810(e)(2).

51. *Id.* §§ 809(e)(1), -810(e)(1).

adjudicating speed camera cases, the standard of liability is a preponderance of the evidence.⁵² On the defendant driver’s side, defenses may include (1) “that the motor vehicle or registration plates of the motor vehicle were stolen before the violation occurred;” (2) that the cited driver “was not operating the vehicle at the time of the violation;” and (3) “[a]ny other issues and evidence that the District Court deems pertinent.”⁵³

D. Case Law

Since the civil penalty is so low and no detriment attaches to a violator’s driving record or insurance eligibility, it is not surprising that only one case under the speed monitoring statutes has advanced to the Maryland Court of Appeals.⁵⁴ In the ironic case of *State v. Cates*,⁵⁵ Montgomery County police officers contested speeding citations under the automated speed monitoring law that were issued to them by their police departments after they were caught by the cameras exceeding speed limits when operating their police vehicles on duty, but not in response to an emergency.⁵⁶ The Court of Appeals of Maryland vacated and remanded the circuit court’s dismissal of the tickets (as the result of a trial *de novo* following the district court’s findings of guilt), holding that the police department’s internal procedure for re-issuing citations that had been issued to the department as the owner of the police vehicles to officers driving the vehicles did not violate the officers’ due process rights.⁵⁷

The court in *Cates* found that the police officers were subject to liability like any other driver for operating their vehicles in excess of the speed limit, even while on duty.⁵⁸ It also found that the officers were not deprived of due process, but instead were afforded ample opportunity to contest their liability in district court and in a trial *de novo* in the circuit court pursuant to the speed monitoring enforcement statute.⁵⁹ Interestingly for drivers contesting speed camera violations under these statutes, the court further held that in addition to the defenses specifically named in the statutes, defendants “may also argue that the State has failed to meet the numerous requirements of TA Section 21-809,” including the specific elements of the required “recorded image” of the citation, the certificate of training for the speed monitoring system operator from the system’s manufacturer, the daily set-up

52. *Id.* §§ 809(e)(3), -810(e)(3).

53. *Id.* §§ 809(f)(1), -810(f)(1).

54. *See infra* notes 55–62 and accompanying text.

55. 12 A.3d 116 (Md. 2011).

56. *Id.* at 118–19. The district court ruled against the officers because they violated the speed limit in a non-emergency situation. *Id.* at 118.

57. *Id.* at 126–30 (stating that informal procedures may satisfy due process as long as they are neither unfair nor arbitrary, that the re-issuance of the citation to the officers was not unfair, and that the officers in this case had opportunities to appeal the citations at both the district and circuit court levels).

58. *Id.* at 119.

59. *Id.* at 128–30.

log, and the signed certificate from an independent calibration laboratory.⁶⁰ These “defenses” are not expressly named in the statutes themselves, thereby making *Cates* an important precedent for making such arguments in future cases.

One rare speed camera case outside of Maryland is also worth mentioning. In *City of Cleveland Parking Violations Bureau v. Barnes*,⁶¹ a speeding ticket from an automated traffic enforcement camera was challenged through the statutory administrative procedure and then on appeal to the trial court.⁶² After those bodies affirmed the ticket, the driver appealed to the Ohio Court of Appeals.⁶³ That court ruled in favor of the city on the procedural grounds raised by the driver, but found in the driver’s favor that signs must be posted to warn of the presence of a mobile camera unit, just as they are with fixed camera units.⁶⁴ “To find to the contrary,” the court stated,

*would create two classes of citizens similarly situated and treat them unequally: those ordinary observant motorists that received no notice that they are approaching an area where a mobile automated camera is monitoring for red light or speed violators and those ordinary observant motorists that received notice that they are approaching an area where a fixed or stationary automated camera is monitoring for red light or speed violators.*⁶⁵

The immediate importance of the *Barnes* case is that motorists hit with tickets from mobile speed camera units that are not equipped with adequate signage are entitled (in Ohio, at least) to a measure of “equal protection” with motorists who are caught by stationary units whenever the governing statute requires signage for the latter but is vague about signage for the former.⁶⁶ More subtly, *Barnes* suggests that there are two classes of motorists—those who know about the speed camera (usually the locals) and those who do not (usually out-of-towners).⁶⁷ In the case of an ordinary police officer-manned speed trap, these separate classes do not exist because neither type of class member knows when the police officer will man the speed trap.⁶⁸ Speed

60. *Id.* at 119 & n.4 (citing MD. CODE ANN., TRANSP. §§ 21-809(a)(4)(ii), -809(b)(2)–(4) (West 2010)).

61. No. 94502, 2010 WL 5238601 (Ohio Ct. App. Dec. 16, 2010).

62. *Barnes*, 2010 WL 5238601, at *1.

63. *Id.* at *4. *Barnes* appealed on the grounds that he did not receive notice of the mobile speed unit location as required by statute. *Id.*

64. Because the city failed to comply with the statutory requirement to post signs alerting drivers to all automated traffic enforcement camera systems, the court found that *Barnes* was not liable for the citation. *Id.* at *5.

65. *Id.*

66. *See id.* (holding that “the plain words of the statute require the posting of signs for all automated traffic enforcement camera systems, including those placed in mobile units”).

67. *See supra* text accompanying note 65.

68. *See, e.g.*, SPEED TRAPS: HOW DO SPEED TRAPS WORK?, 1stRadarDetectors.com (Apr. 24, 2008), http://www.1stradardetectors.com/news/How_Do_Speed_Traps_Work%3F.html (noting that law enforcement

cameras, by contrast, are *always* present at their designated locations, so nonresidents are at a distinct disadvantage.⁶⁹ The implications of this line of reasoning on the constitutional “right to travel” may one day be worth pursuing in the larger context of mass speed camera enforcement systems.⁷⁰

III. SPEED CAMERA TECHNOLOGY

Several automated traffic enforcement vendors have been competing vigorously for local business in Maryland.⁷¹ They include Affiliated Computer Services, Inc. (ACS);⁷² Redflex Traffic Systems, Inc.;⁷³ Traffipax, Inc. (recently renamed Jenoptik);⁷⁴ Optotrafic;⁷⁵ and American Traffic Solutions California (ATS), also known as LaserCraft, Inc.⁷⁶ Several of these are large multinational companies.⁷⁷

According to a 2009 staff report by the Police Chief of the City of Bowie to her City Manager, the Bowie Police Department chose ACS, a joint venture of Cisco Systems, Inc. and Xerox Corporation, to run the city’s automated speed monitoring enforcement program.⁷⁸ She reported that the company charged the city no up-front costs for the installation of speed cameras.⁷⁹ Of each paid citation fee of \$40, ACS would receive \$16.25.⁸⁰ ACS provides all processing and customer services

speed traps utilize “elements of stealth and surprise” to detect speeding drivers and issue warnings and citations).

69. See, e.g., Press Release, National Motorist Association, A Speeding Ticket by Mail? It Could Happen To You This Holiday Weekend (July 2009), *available at* <http://www.motorists.org/press/speeding-ticket-by-mail-holiday-weekend>. “Local residents are usually well aware of the quirks of their community’s traffic laws, but unfortunately most out-of-state visitors don’t have that luxury . . . Motorists who don’t live in areas with speed cameras are likely to be taken completely by surprise by these automated ticketing machines.” *Id.*

70. See *Aptheker v. Sec’y of State*, 378 U.S. 500, 505 (1964) (stating that “[t]he right to travel is a part of the ‘liberty’ of which the citizen cannot be deprived without due process of law under the Fifth Amendment” (quoting *Kent v. Dulles*, 357 U.S. 116, 125–26 (1958))).

71. See Interoffice Memorandum from Katherine A. Pérez, Chief of Police, Bowie, Maryland to David J. Deutsch, City Manager, Bowie, Maryland (Oct. 15, 2009), *available at* http://www.cityofbowie.org/StaffReports/Staff_reports2009/1019_speed_camera_vendor_att1.pdf [hereinafter Pérez Memorandum] (reporting that Affiliated Computer Services, Inc. was selected from among a number of competing speed camera service providers).

72. AFFILIATED COMPUTER SERVICES, INC., <http://www.acs-inc.com/public-safety-services/photo-enforcement-program.aspx> (last visited Sept. 25, 2011).

73. REDFLEX TRAFFIC SYSTEMS, <http://www.redflex.com/html/usa/index.php> (last visited Sept. 25, 2011).

74. JENOPTIK, http://www.jenoptik.com/en_4_traffic_solutions (last visited Sept. 25, 2011).

75. OPTOTRAFFIC, <http://optotrafic.com/> (last visited Sept. 25, 2011).

76. AMERICAN TRAFFIC SOLUTIONS, LASERCRAFT, <http://lasercraftinc.com/index.php> (last visited Sept. 25, 2011).

77. See, e.g., Pérez Memorandum, *supra* note 71 (noting that ACS is a Fortune 500 corporation with over 70,000 employees worldwide).

78. See *id.* (noting that ACS has fifteen years of photo enforcement and current speed camera programs in place with Montgomery County, Rockville, Chevy Chase, Gaithersburg, and Takoma Park).

79. *Id.*

80. *Id.*

required of the program.⁸¹ The program is overseen by the City of Bowie Police Department, and verifications are conducted by police officers.⁸²

Several U.S. patents on automated traffic enforcement technology were issued starting in the 1980s.⁸³ One is U.S. Patent No. 5,515,042 entitled “Traffic Enforcement Device,” issued to Lorry Nelson on May 7, 1996,⁸⁴ which is still in force and describes a mobile speed camera system.⁸⁵ The figures of the patent depict all of the relevant aspects of this technology:

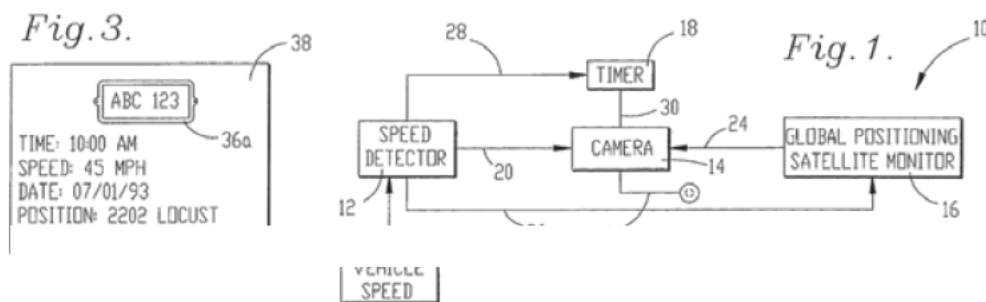
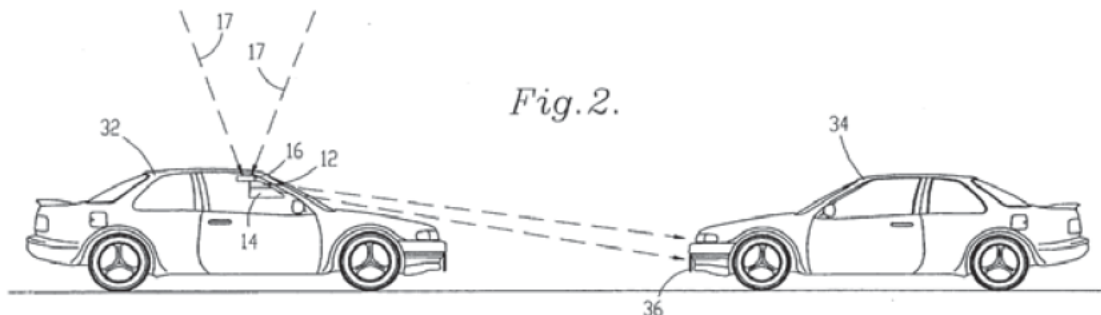

As can be seen from Figure 2, a mobile speed monitoring unit (32) is used to detect vehicles traveling in excess of posted speed limits (34).⁸⁶ The flowchart in Figure 1 shows how the system functions. A motor vehicle’s speed in excess of a predetermined magnitude (in Maryland, 12 mph over the posted speed limit) is

81. *Id.*

82. *Id.*

83. See, e.g., Traffic Radar Device, U.S. Patent No. 4,236,140 (filed Apr. 14, 1978) (issued Nov. 25, 1980), available at <http://www.freepatentsonline.com/4236140.pdf> (patenting a traffic radar device for the facilitation of Doppler signal processing).

84. Traffic Enforcement Device, U.S. Patent No. 5,515,042 (filed May 7, 1996) (issued Jan. 20, 1995), available at <http://www.freepatentsonline.com/5515042.pdf>.

85. The ‘042 Patent describes a mobile speed monitoring device that can detect a speeding violation and create a “vehicle identifying image.” *Id.*

86. ‘042 Patent, at col. 3 ll. 47–52 (“In use, the monitoring vehicle 32 would proceed among normal traffic with the detector 12 operating. This would be in a manner exactly analogous to conventional radar or laser detectors now in use, i.e., the operator vehicle 32 would position the vehicle so as to properly monitor successive vehicles 34 in the traffic stream.”).

detected by a radar or laser speed measuring device (12) that triggers a timer (18) and a still or video camera (14) to record an image of the car's license plate and images of the entire car (Fig. 3) together with the snapshot times for the purpose of creating a record of the violation (38).⁸⁷ In this mobile system, a GPS system (16) is also incorporated in order to record the system's position on the ground as part of the violation record (38).⁸⁸ The system can be triggered manually to record images, or can be set to record images automatically.⁸⁹ It is important to note that, in order to capture on film a non-blurry image of a vehicle moving at a high rate of speed at a considerable distance from the camera, high-speed, high-intensity flash bulbs are also necessary to take good photographs.⁹⁰

Most systems record two photographic images of a moving motor vehicle that record the camera trigger times down to tenths of a second.⁹¹ Ideally, they also record the vehicle traveling over a series of stripes painted on the road that are a fixed distance apart from one another (usually five feet) in order to better show how far the vehicle moved during the time interval between the two photographs.⁹² The following, from a District of Columbia speed camera,⁹³ is an example:



Picture 1



Picture 2

87. See '042 Patent ("When a monitored vehicle's speed exceeds a predetermined magnitude, the detector (12) generates an output serving to initiate operation of the camera (14) and satellite monitor (16), and to deliver speed information to the camera (14). The camera (14) creates a vehicle-identifying image (38), and imposes on the image (38) the speed and position information.").

88. '042 Patent, at col. 3 ll. 19–23.

89. *Id.* at col. 3 ll. 7–11.

90. See U.S. DEP'T OF TRANSP., SPEED ENFORCEMENT CAMERA SYSTEMS OPERATIONAL GUIDELINES § 2 at 12 (2008) (stating that fast shutter speed and high image resolution are optimal for speed camera image capture).

91. *Id.* at 15.

92. *Id.*

93. Speed Camera Traffic Citation (Jan. 31, 2011, 13:02:34) (on file with author). The vehicle shown belongs to the author, who did not contest the ticket and paid the \$125 fine.

As the images show, the subject vehicle is shown in Pictures 1 and 2 on January 31, 2011, at 13:02:34 EST.⁹⁴ Picture 2 is imprinted as having been taken 0.2 seconds after Picture 1, all happening within second “34” as indicated by the time-stamp.⁹⁵ The back tire of the vehicle is shown traveling approximately three five-foot road stripes from its location in Picture 1 to its location in Picture 2, a total of approximately 15 feet. The car is detected and recorded as having traveled 56 mph, 11 mph over the 45 mph speed limit, constituting a violation under D.C. traffic law.⁹⁶ Converting 56 mph into feet per second, the recorded speed of the car is 82.13 feet per second (i.e., 56 miles/hour x 5,280 feet/second ÷ 3,600 seconds/hour = 82.13 feet per second).⁹⁷ Thus, in the 0.2 seconds between Picture 1 and Picture 2, the car traveled 16.43 feet (i.e., 82.13 feet/second x 0.2 second = 16.43 feet).⁹⁸ The visual motion of the car, therefore, matches its mechanically recorded motion within approximately one and one-half feet of accuracy. This measurement is probably accurate enough to sustain the violation in traffic court.⁹⁹

IV. PROBLEMS IN ADMINISTRATION AND ENFORCEMENT

Speed cameras yield impressive enforcement results.¹⁰⁰ In the city of Bowie, Maryland alone, the “Bowie Safe Speed Program” captured more than 86,000 violators within the year of its inception.¹⁰¹ Under the arrangement between Bowie and ACS mentioned above, this success rate translates into over \$2 million in net revenue for the city.¹⁰² As for non-violators, the presence of speed cameras has a demonstrable *in terrorem* effect on moderating traffic speeds, even inducing some drivers to pass the camera locations at speeds well below the limit.¹⁰³

Although municipalities in Prince George’s County have eagerly implemented speed camera systems in school zones within their boundaries, the county itself was

94. *Id.*

95. *Id.*

96. See generally D.C. CODE § 50-2209.01 (2009) (authorizing the use of automated traffic enforcement systems to detect moving violations); D.C. MUN. REGS. tit. 18, § 2600.1 (2009) (authorizing fines where alleged violators exceed the speed limit by 10 mph).

97. See ROGERS D. RUSK, INTRODUCTION TO COLLEGE PHYSICS xviii, 62, 63 (Appleton-Century-Crofts, Inc. 1954) (defining speed as equal to distance divided by time, $s=d/t$).

98. By applying basic algebra, the equation for speed can be rearranged to solve for time and distance, which equals speed multiplied by time ($d=st$). *Id.*

99. See, e.g., People v. Barbaric, 244 N.E.2d 626, 639 (Ill. App. 2d 1969) (upholding a lower court conviction where the court found reasonable and sufficient proof of the accuracy of the instrument).

100. See Van Cleave, *supra* note 2 (reporting that five cameras alone in Maryland have generated over \$15 million in revenues since 2009).

101. Joe Aiello, *New Speed Cameras Flashing Soon*, BOWIE-BLADE NEWS (June 23, 2011), <http://www.hometownbowie.com/content/new-speed-cameras-flashing-soon>.

102. See Pérez Memorandum, *supra* note 71; see also Aiello, *supra* note 101 (multiplying the gross revenue to the City of Bowie in the amount of \$23.75 per citation by 86,000 violators cited since the program’s inception).

103. According to the Evaluation of Montgomery County’s Safe Speed Program, the percentage of cars passing the camera at or below the speed limit rose from 73% to 87% after thirteen months of speed camera activation. See ROMER ET AL., *supra* note 1, at iii.

slow to adopt them on its own roads at first, citing their relative unpopularity.¹⁰⁴ By the middle of 2011, however, the county developed plans to install more than 100 of the devices at county school sites.¹⁰⁵

Notwithstanding the clear impact of speed cameras on moderating human driving behavior, the technology itself is not infallible.¹⁰⁶ Mechanisms can and do go awry, and the human beings who operate them can and do make mistakes.¹⁰⁷ Several are worthy of note here.

Some speed camera devices do not record the time between the two photographs in tenths of a second; even if they can do so, many are not set up by their operators to do so. The two photographs of each violation that the devices take sometimes show the times of the snapshots only as the same second, i.e., as “13:02:34” in both pictures of the example above.¹⁰⁸ Without knowing the precise moment when each photograph was taken, it is impossible to say for certain how fast a vehicle was going between the takings of the two photographs.¹⁰⁹

For instance, in the above example, if the 0.2 second time differential between the two photographs were not imprinted on the photographs, then we would only know that the pictures were taken sometime within “second 13:02:34.” Giving the motorist the benefit of the doubt (as we must do, since the burden of proof is on law enforcement), we must therefore assume that the two pictures were taken at most one second apart.¹¹⁰

If the car in the above example were indeed traveling at 56 mph as the speed camera equipment recorded, then it would have traveled 82.13 feet during that single second, as already explained.¹¹¹ Yet the two photos show the car traveling only about 15 feet.¹¹² Indeed, if the car traveled only 15 feet in that single second, then it would have been going at a speed of only 10.23 mph (i.e., 15 feet/second x 3600 seconds/hour ÷ 5,280 feet/mile = 10.23 miles/hour), well under the posted 45 mph speed limit.¹¹³ Given the critical absence of the precise time interval between

104. See Daniel Valentine, *Prince George’s Residents Seek Assurance That New Speed Cameras Will Be Closely Monitored*, GAZETTE.NET (July 13, 2011), <http://www.gazette.net/article/20110713/NEWS/707139181&template=gazette> (noting that despite a 2009 resolution authorizing the speed cameras, “the county held off . . . because of their unpopularity”).

105. *Id.*

106. See Tarron Lively, *Doubts Rise on Traffic Cameras; AAA Calls Reports of Malfunctions ‘Tipping Point,’* WASH. TIMES, Mar. 15, 2007, at B03 (reporting in 2007 that over half of Washington D.C.’s speed cameras were found to be malfunctioning or damaged).

107. See Brian DeBose & Matthew Cella, *District to Void Speeding Tickets; Wrong Limits Led to 2,438 Citations*, WASH. TIMES, Nov. 30, 2002, at A01 (stating that more than 2,000 drivers were issued citations in error when a speed camera was set up prior to an upward adjustment in the legal speed limit).

108. See *supra* notes 93–95 and accompanying text.

109. See, e.g., U.S. Patent No. 7,616,293 col. 17 ll. 19–30 (filed Apr. 29, 2005) (stating that factors such as the vehicle’s speed and laser beam spot separation may contribute to uncertainty in absolute speed estimation using lasers).

110. U.S. DEP’T OF TRANSP., *supra* note 90, at 37.

111. See RUSK, *supra* note 97 and accompanying text.

112. See RUSK, *supra* note 98 and accompanying text.

113. See RUSK, *supra* note 97, at xviii, 63.

the taking of the two photographs and the inherent uncertainty of measuring the car's speed with the information provided, a district court judge would have insufficient evidence to tell how fast the car was really going and would have to dismiss the ticket.¹¹⁴

Another problem with speed camera use is the frequent lack of markings on the street that indicate how far the vehicle traveled between the two photographs.¹¹⁵ Although the statutes require the two photographs of a vehicle to show “the same stationary object near the motor vehicle,”¹¹⁶ they do not require the photographs to show equally-spaced road stripes in the camera's field of view that would locate the vehicle more precisely.¹¹⁷ For example, compare the photographs in the District of Columbia example above, which shows such road stripes, with the following photograph taken by a speed camera in Bowie, Maryland:¹¹⁸



There is an identical “stationary object” in both pictures as the law requires; namely, the utility pole some distance away from the car.¹¹⁹ However, there are no markings in the street that show how far the visible rear wheel of the car traveled

114. See, e.g., U.S. Patent No. 7,616,293 col. 17 ll. 19–30 (filed Apr. 29, 2005) (issued Nov. 10, 2009) (discussing that laser beam technology may be made more accurate by “increasing the separation between the two laser spots,” “increasing the laser repetition rate,” and “decreasing the laser spot size”).

115. The Evaluation of Montgomery County's Safe Speed Program emphasized the importance of calibrating and testing equipment at mobile and fixed sites, noting the use of road cones for mobile speed cameras, and progression lines on the roadway for fixed speed cameras. See ROMER ET AL., *supra* note 1, at 34.

116. MD. CODE ANN., TRANSP. §§ 21-809(a)(4)(ii), -810(a)(4)(ii) (West 2010).

117. *Id.*; see generally Ken Leiser, *MoDOT to Charlack: Remove I-170 Stripes for Speed Cameras*, ST. LOUIS POST-DISPATCH, at A1 (Sept. 24, 2010) (reporting conflict between transportation authorities and local officials regarding painted lines on roadways used to calibrate speeding cameras); Susan Singer-Bart, *Damascus Man Challenges Ridge Road Speed Camera*, GAZETTE.NET (Mar. 9, 2011), http://ww2gazette.net/stories/03092011/damanew223020_32526.php (noting one element of a resident's challenge was the fact that stripes on the roadway indicating the location of the camera were closed off due to construction).

118. Speed Camera Traffic Citation at Northbound 7700 Laurel-Bowie Road in Bowie, Maryland (Feb. 2, 2011, 11:56:47 AM EST) (on file with author).

119. TRANSP. §§ 21-809 (a)(4)(ii)(2), -810 (a)(4)(ii)(2).

between the takings of the two photographs. This deficiency, in addition to the fact that the photos show the car moving away at an angle, make precise measurement of the car's movement extremely difficult.¹²⁰ Nevertheless, by juxtaposing the two pictures on a computer screen in "slide show" format, the author was able to demonstrate to a district court judge that the car traveled only one car length, calling the accuracy of the camera measurement into question and causing the ticket to be dismissed.¹²¹

The law requires speed cameras to be calibrated annually and for system operators to self-test the devices daily.¹²² However, just because these tests are performed does not mean that speed camera equipment, which is typically left unmanned for an entire day, cannot malfunction during that day.¹²³ Anyone who has operated a computer knows how finicky they are, and one can only imagine what a computer locked in a metal cabinet for an entire day, experiencing all the changes in temperature and weather during that day, will do.¹²⁴ Moreover, the law does not require the system operator performing the self-test on a speed camera device to record whether she discovered the device to be malfunctioning when she got there; she is only required to re-boot the machine and perform the self-test on the re-booted machine.¹²⁵ Without any record of how far off a machine has gotten during the course of a day, there is no way to tell whether it is likely to remain accurate over the course of the following day, or if it is consistently accurate at all.¹²⁶

One anecdotal example that the author learned of along these lines was of a speed camera in the town of Riverdale Park, Maryland that recorded a motorist's car traveling along a two-lane road in the town at 64 mph, in a 35 mph zone. At his district court hearing, the irate motorist told the author that he had a clean driving record going back about 25 years, that he was notorious among his friends for being

120. See generally '293 Patent, at col. 19 ll. 8–15 (describing how laser sources in the speed detection system may be focused to narrow lines on the road surface and noting that the most advantageous configuration is when the focus-spot is perpendicular to the direction of traffic to minimize speed uncertainty).

121. Cf. David Hill, *Business Owner Casts Reasonable Doubt on Accuracy of Speed Cameras*, WASH. TIMES, Apr. 20, 2011, <http://www.washingtontimes.com/news/2011/apr/20/business-owner-casts-reasonable-doubt-on-accuracy-/print/> (reporting on the successful dismissal of multiple speed camera citations detected by Optotrafic systems in Prince George's County).

122. TRANSP. §§ 21-809(b)(3)–(4), -810(b)(5)–(6).

123. See, e.g., ROMER ET AL., *supra* note 1, at 35 (reporting that speed camera violations were rejected because of an equipment malfunction or power interruption).

124. See U.S. DEP'T TRANSP. ET AL., SPEED-MEASURING DEVICE PERFORMANCE SPECIFICATIONS: ACROSS THE ROAD RADAR MODULE § 2.7 (2007) (describing tests that should be conducted to ensure performance in temperatures ranging from -22°F to 140°F and humidity exposure up to 90% at 99°F for a minimum of eight hours). Companies such as Jenoptik offer enhanced speed camera outer housing to withstand extreme heat and cold. Jenoptik AG Traffic Solutions, *Product Specification for Enhanced Climate Outer Housing for Extreme Heat and Cold*, <http://www.jenoptik.com/en-climate-housing-for-fixed-traffic-enforcement-systems> (last accessed Sept. 25, 2011).

125. See TRANSP. §§ 21-809(b)(3)(i), -810(b)(5)(i)–(ii) (requiring that the operator successfully perform the manufacturer-specified self-tests and record that the device passed).

126. See MD. ST. HIGHWAY ADMIN., GUIDELINES FOR AUTOMATED SPEED ENFORCEMENT SYSTEMS IN SCHOOL ZONES 8 (rev'd 2011) (advising that local jurisdictions are responsible for system calibration and maintenance in accordance with state or local law and manufacturer's specifications).

a “pokey driver,” and that he could not imagine himself driving at such a reckless speed down the road in question.¹²⁷ The evidence against him consisted of two speed camera photographs, imprinted as having been taken 0.3 seconds apart, in which his back wheels traveled a distance of 19 feet between two fence-posts that he measured prior to his court date. A car traveling 64 mph in 0.3 seconds would have gone 28.16 feet (i.e., 64 miles/hour x 5,280 feet/mile ÷ 3600 seconds/hour x 0.3 second = 28.16 feet).¹²⁸ If he had indeed traveled only 19 feet in 0.3 seconds, as the photos seemed to indicate, the motorist would have had to have been driving at a speed of only 43.18 mph (i.e., 19 feet ÷ 0.3 seconds x 3600 seconds/hour ÷ 5,280 feet/mile = 43.18 miles/hour), only eight mph over the speed limit and well within the 12 mph “safe harbor” over the speed limit that the law allows.¹²⁹ Even if the speed camera had been self-tested at the beginning of that day prior to the alleged violation, it would be safe to assume that it malfunctioned at some point prior to recording this motorist’s speed.¹³⁰ In any event, the motorist should not have been found guilty of a violation on the basis of such contradictory evidence.¹³¹

Another error occurs in work zones along expressways. These areas are typically monitored by speed camera devices mounted on small trucks parked in the work zone or on an adjacent shoulder.¹³² Once the trucks are parked, the operator of the truck typically leaves the truck and goes about his business, letting the truck do its work automatically. However, the speed camera law for work zones expressly provides that “[a] work zone speed control system may be used *only [w]hen* being operated by a work zone speed control system operator.”¹³³ A cited motorist is entitled to request the presence of a speed control system operator 20 days prior to trial,¹³⁴ at which time “an” operator (not necessarily *the* operator who actually took the picture of the alleged violator)¹³⁵ can be questioned under oath as to the actual operator’s whereabouts at the time of the violation in question.¹³⁶ In order to

127. Cf. *Maryland Speed Camera Program Faces New Legal Challenge*, CARROLL STANDARD (Apr. 30, 2010, 4:30 PM), <http://carrollstandard.com/news/in-other-news/8398-maryland-speed-camera-program-faces-new-legal-challenge.html> (noting a driver’s surprise upon receiving a speed camera citation, her first in forty years of driving).

128. See RUSK, *supra* note 97, at xviii, 63.

129. See MD. CODE ANN., TRANSP. §§ 21-809(a)(5), -810(b)(3) (authorizing the use of speed control systems to record the images of vehicles traveling “at speeds at least 12 mph above” the legal speed limit).

130. See *generally supra* notes 123–26 and accompanying text.

131. See TRANSP. § 21-809(f)(1)(iii) (permitting the district court to consider any other issues or evidence deemed pertinent as defense to a speed camera violation).

132. See *generally* TRANSP. § 21-809(a)(6) (defining “work zone speed control system” as “a device having one or more motor vehicle sensors connected to a camera system capable of producing recorded images of motor vehicles traveling at or above a predetermined speed in or approaching a work zone”); Ashley Halsey III, *Md. Cameras Catch Thousands of Work Zone Speeders*, WASH. POST, Jan. 20, 2010, at B03 (reporting that work zone speed cameras are repositioned daily in parked SUVs).

133. MD. CODE ANN., TRANSP. § 21-810(b)(2)(ii) (West 2010) (emphasis added).

134. *Id.* § 810(e)(2).

135. The code states “if a person . . . desires a work zone speed control system operator to be present and testify at trial[;]” it does not state if a person desires *the* work zone speed control system operator. *Id.*

136. See *id.* (stating that the system operator shall be present and testify at trial upon request).

further test the operator's credibility, the motorist could even drive by the (hopefully still-active) work zone before trial, take a picture of the truck, and query the testifying operator about normal operating procedures if the truck proves to be unmanned.¹³⁷

Although local jurisdictions in Prince George's County may consider automated speed camera enforcement to be a godsend for their treasuries,¹³⁸ the Maryland law contains hidden traps for unwary cities and towns as well as for motorists.¹³⁹ For one, the law provides that "[a] speed monitoring system may not be used in a local jurisdiction under this section unless its use is authorized by the governing body of the local jurisdiction by local law enacted after reasonable notice and a public hearing."¹⁴⁰ There is considerable variation and inattentiveness among local communities in meeting this requirement.¹⁴¹

In Bowie, the City Council passed an ordinance that authorizes the City Council, "by Resolution, following reasonable notice to the public and a public hearing," to establish a school zone on any road in the city within one-half mile of a school.¹⁴² However, there is no public record of the Bowie City Council ever having passed any "Resolution" specifically designating such zones in specific places; the city has simply left it up to the City Manager and the police department to announce implementation of the zones, without any public hearing.¹⁴³ Such procedural failures on the part of local jurisdictions may be fatal enough to invalidate thousands of tickets that they have issued and have been paid by motorists without contest, necessitating refunds that could set these communities back to the tune of thousands of dollars.¹⁴⁴

Another potential trap for the unwary town lies in the requirement for an annual calibration check and certification of the machines that must be performed,

137. *Cf. supra* note 133 and accompanying text.

138. *See, e.g.,* Andrew White, *Smiles, and Frowns, for the Speed Cameras*, WASH. TIMES, Jan. 20, 2011, at T17 (reporting that revenue from speed cameras will generate \$580,000 for Forest Heights, or 10% of the fiscal year's 2011 budget).

139. *See infra* notes 140–41 and accompanying text; *see generally* VIRGINIA TRANSPORTATION RESEARCH COUNCIL, AUTOMATED SPEED ENFORCEMENT PILOT PROJECT FOR THE CAPITAL BELTWAY: FEASIBILITY OF PHOTO-RADAR 10-26 (1992) (providing an overview on the potential constitutional, evidentiary, and chain of custody concerns regarding photo-radar speed enforcement).

140. MD. CODE ANN., TRANSP. § 21-809(b)(1)(i) (West 2010).

141. *See infra* text accompanying notes 142–145.

142. BOWIE, MD., CODE § 14-17B(b)(1) (2010), *available at* <http://www.cityofbowie.org/Government/Code/CodeBinder.pdf>.

143. *Id.*; *see also* Minutes of the City of Bowie Regular City Council Meeting, City Manager's Report, 2 (June 6, 2011), *available at* <http://www.cityofbowie.org/StaffReports/2011/0620min0606.pdf> (stating that the process is underway to obtain permits for installing speed cameras but fails to mention a public hearing or passage of a resolution). A search of the Bowie Internet Laserfiche Document Center Resolutions archive for 2009, 2010, and 2011 did not reveal any results for the city's speed camera program (as of Sept. 10, 2011).

144. Other jurisdictions have invalidated speed camera tickets en masse for other procedural deficiencies. *See supra* note 107 (detailing invalidation of more than 2,000 speed camera citations and reimbursement of \$72,000 in fines in Washington D.C.).

according to the statutes, by “an independent calibration laboratory.”¹⁴⁵ Most speed camera programs in Prince George’s County are too new for their devices to have undergone their first annual calibration check as of yet, but such checks of every device by a truly “independent” laboratory (that is, one that is not an affiliate of the manufacturer) probably will not be cheap.¹⁴⁶ What is more, as explained above, these potentially expensive calibrations still will not guarantee to the local jurisdictions that the devices will remain calibrated throughout a typical day of use.¹⁴⁷ It will be interesting to see if these cash-strapped communities will enter into contracts with qualified labs in a timely manner in order to have these calibration checks done, and if not, what impact on the enforcement of future speed camera violations any delay or questionable contract will have.

V. PROBLEMS FOR THE JUDICIARY

There are also concerns that should particularly trouble members of the Maryland District Court judiciary who are tasked with trying speed camera enforcement cases.¹⁴⁸ It is their courts and dockets that are now being clogged as never before with speed camera tickets.¹⁴⁹

Speed camera tickets confront judges with one of their most hated dilemmas: either dispense cases quickly with less justice; or be more judicious with each case, only to lengthen each trial day and face hundreds more cases tomorrow. The state of Maryland has done nothing whatsoever to help district court judges or increase their budgets in order to handle the burgeoning caseload.¹⁵⁰ Certainly the companies that manufacture and sell speed cameras have done little or nothing to help the courts carry out their statutory mandate, despite the requirement in the law that “[a]n agency or an agent or contractor designated by the agency shall administer and process civil citations issued under this section in coordination with the District Court.”¹⁵¹ At best, the district courts have tried to manage the caseload

145. MD. CODE ANN., TRANSP. § 21-809(b)(4)(ii) (West 2010).

146. See SPEED CAMERAS SAVE MONEY, The Nat’l Safety Comm’n (Aug. 16, 2011), <http://alerts.nationalsafetycommission.com/2011/08/speed-cameras-save-money.html> (reporting on the debate as to whether speed cameras are worth the cost of their maintenance after drivers begin abiding speed limits and citation revenues fall).

147. See *supra* text accompanying notes 122–126.

148. See MD. CODE ANN., CTS. & JUD. PROC. § 4-401(13) (West 2010) (granting the Maryland District Court exclusive original civil jurisdiction over civil infractions under speed monitoring system statutes).

149. Courts in Montgomery County heard 3,098 appeals to speed camera citations in fiscal years 2008 and 2009. ROMER ET AL., *supra* note 1, at 35. Speed camera cases are dominating the dockets of some other states’ courts as well. See, e.g., Amy B. Wang, *Maricopa County Supervisors OK Additional Speed-Camera Fee*, THE ARIZONA REPUBLIC (Nov. 4, 2009), available at <http://www.azcentral.com/news/articles/2009/11/04/20091104-speedcamerafees1104.html> (noting that speed camera cases in Arizona represent half of all court filings).

150. Comparing Maryland District Court’s proposed fiscal 2012 budget with the 2010 actual budget and the 2011 appropriations, the number of authorized positions remains flat at 1,391.50 while the number of contractors has increased by only 15 positions. MD. DEP’T OF MGMT. & BUDGET, MARYLAND STATE BUDGET: JUDICIAL AND LEGAL REVIEW 1-33 (2012), available at <http://dbm.maryland.gov/agencies/operbudget/Documents/2012/Proposed/judlegal.pdf>.

151. MD. CODE ANN., TRANSP. § 21-809(j)(1) (West 2010).

by holding mass hearings for individual cities and towns on specific days of each month, causing great inconvenience for defendants who cannot take time off from work to appear in court on “Bowie Day” or “College Park Day.”¹⁵²

What is more, the insignificant amount of the fine renders appeal of adverse cases virtually impossible for motorists.¹⁵³ The filing fee for *de novo* review of district court cases by the Maryland circuit courts, and the fees for appeal to higher courts, far exceed the fine itself.¹⁵⁴ This makes the district court judge’s bromide that “you are always free to appeal my decision” particularly frustrating to the motorist who believes that he has unjustly been found guilty. The paucity of appellate decisions also leaves district court judges bereft of guidance from higher courts on how to interpret and apply the speed camera laws.¹⁵⁵ At the very least, the Maryland legislature would be well-advised to remove all appellate filing fees from such cases in order to assure an adequate chance of judicial review.

The speed camera laws also contain a flaw that calls the evidence judges hear in such cases into question.¹⁵⁶ Under the statutes, the evidence of a violation in such cases consists of a certificate alleging that the violation occurred and the requirements of the statute have been satisfied that is sworn to or affirmed by either “an agent or employee of” the enforcing agency or, in the case of work zones, by a police officer of the enforcing jurisdiction, “based on inspection of recorded images produced by a work zone control system.”¹⁵⁷ It is admissible in court without the presence or testimony of the system operator who performed the daily testing requirements on the device in question.¹⁵⁸

This is very different from the usual evidentiary requirement typified by Rule 602 of the Federal Rules of Evidence,¹⁵⁹ which forbids a non-expert witness to testify unless the witness has “personal knowledge of the matter.”¹⁶⁰ It also differs from the standard practiced by Maryland district courts in normal radar speed cases, in which the police officer who operated the radar and observed the alleged violator exceeding the speed limit is called upon to testify of his own personal knowledge.¹⁶¹

152. In order to manage the caseload, the district court in Montgomery County schedules between 100 and 200 speed camera citation hearings for a single morning once each month. See ROMER ET AL., *supra* note 1, at 34.

153. TRANSP. § 21-809(c)(2).

154. See DIST. CT. OF MD., GUIDE TO APPEAL FEES (2010), available at <http://www.courts.state.md.us/district/forms/acct/dca109a.pdf> (authorizing an \$80 appeal fee for speed monitoring citations).

155. See *supra* notes 46–47.

156. See *infra* text accompanying notes 157–63.

157. MD. CODE ANN., TRANSP. §§ 21-809(e)(1), -810(e)(1) (West 2010).

158. *Id.*

159. FED. R. EVID. 602.

160. “A witness may not testify to a matter unless evidence is introduced sufficient to support a finding that the witness has personal knowledge of the matter. Evidence to prove personal knowledge may, but need not, consist of the witness’ own testimony.” *Id.*

161. See DIST. CT. OF MD., TRAFFIC CITATION INFORMATION, <http://www.courts.state.md.us/district/selfhelp/traffic.html> (last visited Sept. 25, 2011) (noting that “the officer who issued [the] ticket will testify” at trial).

If the officer fails to appear to testify in court, the case is dismissed.¹⁶² Here, by contrast, permitting a violation to rest on the testimony of a non-expert with no personal knowledge of a violation, other than to have reviewed photographs of the alleged violation after the fact, is to allow hearsay to govern guilt or innocence and to invite the testifying witness to speculate (or worse, to lie) about facts surrounding the allegations that have no grounding in personal perception.¹⁶³ Ultimately, even constitutional questions under the Fifth and Sixth Amendments to the U.S. Constitution could arise, even though speed camera proceedings are ostensibly “civil” rather than “criminal” in nature. It is well-established that the Fifth Amendment’s privilege in criminal cases against self-incrimination and the Sixth Amendment’s right of the criminally accused “to . . . be confronted with the witnesses against him. . . .” may be applicable to civil penalty cases if certain factors are present.¹⁶⁴

VI. CONCLUSION

It is readily apparent to the average driver today that the proliferation of speed cameras has had a significant impact on reducing speeding in Maryland.¹⁶⁵ This is particularly true in Prince George’s County, where local jurisdictions have the authority to implement their own speed camera programs, as well as the county.¹⁶⁶ Motorists are definitely more aware now of the presence of speed cameras along the road and they drive accordingly.¹⁶⁷ Some have even taken to driving their cars on “cruise control,” even on local streets, in order to prevent “lead foot syndrome” from leading them astray and falling unwittingly into the clutches of a speed

162. See Leonard R. Stamm, PRACTICE MANUAL FOR THE MARYLAND LAWYER § 15.2 (3rd ed., Md. Inst. for Continuing Prof’l Educ. of Lawyers 2006) (noting that the nonappearance of a police officer often results in a finding of not guilty).

163. See generally FED. R. EVID. 602, advisory committee’s note (1972) (noting that the rule requiring personal knowledge enhances the reliability of the evidence presented).

164. See *Kennedy v. Mendoza-Martinez*, 372 U.S. 144, 168 (1963) (applying criminal constitutional protections in civil penalty cases depending on “whether the sanction involves an affirmative disability or restraint; whether it has historically been regarded as a punishment; whether it comes into play only on a finding of *scienter*; whether its operation will promote the traditional aims of punishment, that is, retribution and deterrence; whether the behavior to which it applies is already a crime; whether an alternative purpose to which it may rationally be connected is assignable for it; and whether it appears excessive in relation to the alternative purpose assigned”); see also *United States v. Halper*, 490 U.S. 435, 447 n.7 (1989) (“[I]n determining whether a particular civil sanction constitutes criminal punishment, it is the purposes actually served by the sanction in question, not the underlying nature of the proceedings giving rise to the sanction, that must be evaluated.”).

165. See, e.g., Colette Luke, *Speeding Tickets Dropped Significantly After the Addition of 3 Cameras*, RIVERDALE PARK-UNIVERSITY PARK PATCH (Oct. 1, 2010), available at <http://riverdalepark.patch.com/articles/speeding-tickets-dropped-significantly-after-the-addition-of-3-cameras> (reporting that the number of tickets “decreased tremendously” since installing speed cameras).

166. See MD. CODE ANN., TRANSP. § 21-809(b)(1)(iii) (West 2010) (authorizing a municipal corporation in Prince George’s County to “implement and use a speed monitoring system . . . on a county highway at a location within its corporate limits”).

167. See ROMER ET AL., *supra* note 1, at ii (reporting on studies that show the deterrence power of the fines from speed limit violations).

camera. Others have acquired devices that warn them while driving if they are exceeding the speed limit, or that create a record of their speed at all times so that they can compare a speed camera violation's measurement with their own car's record.¹⁶⁸

Although the overarching purpose of automated traffic enforcement is a salutary one of slowing down speeders, and even though the \$40 fine is too low for most people to care if the violation is accurate or worth taking time away from work or home to contest,¹⁶⁹ there is still a legal concern that should trouble the conscientious jurist.¹⁷⁰ That is this: Shouldn't a law that imposes strict liability on the motorist for speeding impose an equal duty on law enforcement authorities to comply strictly with the law's administrative requirements?

The Maryland automated speed enforcement laws suffer from an infirmity of technological and legal uncertainty.¹⁷¹ Governments should be leery of putting too much faith in the infallibility of machines and too little in the right of due process for humans.¹⁷²

To the politicians in the Maryland legislature who were responsible for enacting these laws, it must have seemed like a no-brainer to pass them, given the promise from industry lobbyists of easy money by dunning thousands of citizens with fines too small to fight.¹⁷³ It's all in the name of highway safety, they undoubtedly thought; who would bother to question it? In 1765, however, politicians in the British Parliament, thinking the same way, similarly enacted a law that imposed seemingly insignificant stamp taxes on legal papers, certificates, diplomas, magazines, newspapers, and other documents printed in the American Colonies.¹⁷⁴ That folly sparked the American Revolution.¹⁷⁵ The State of Maryland would be wise to pay heed to that history.

168. For example, Trapster, a mobile speed trap sharing system, uses the mobile device's GPS system to alert users when they exceed the speed limit and when a speed camera is nearby. TRAPSTER, <http://www.trapster.com> (last visited Sept. 25, 2011).

169. See ROMER ET AL., *supra* note 1, at 9, 38. Speed camera citation recipients in Montgomery County, Maryland, challenged a mere 0.4% of such citations issued between fiscal years 2007 and 2009. *Id.*

170. See generally *State v. Cates*, 12 A.3d 116 (Md. 2011) (holding that defendants "may . . . argue that the state has failed to meet the numerous requirements" of section 21-809).

171. See *supra* Parts III–IV.

172. See ROMER ET AL., *supra* note 1, at 10 (noting that some opponents argue that automatic speed monitoring leads to "a 'trial by camera,' automatically presuming" the driver's guilt).

173. ACS, Inc., the Maryland contractor for speed camera violations, has reaped \$2.9 million since 2009 from speed monitoring systems. See Cleave, *supra* note 2 and accompanying text.

174. The Stamp Act, 5 George III, c. 12 (1765), *reprinted in* PROLOGUE TO REVOLUTION: SOURCES AND DOCUMENTS ON THE STAMP ACT CRISIS, 1764-1766, 35-43 (Edmund S. Morgan ed., 1959).

175. GREAT DEBATES IN AMERICAN HISTORY 38 (Marion Mills Miller ed., Current Literature Publishing Company 1913).